

Tper per la sostenibilità automobilistico

21 aprile 2021

Dott.ing. Bottazzi Andrea . Responsabile Manutenzione Automobilistica – TPER spa

sommario

- Le spinte macroeconomiche
- Le scelte di sistema
- Il metano compresso e liquido
- La sostenibilità

➤ WHAT IS A „CLEAN“ BUS?

- List of technologies based on the AFI Directive on the deployment of alternative fuels infrastructure (Dir. 2014/94/EU, Art. 2(1) and 2(2))

„CLEAN VEHICLES“

- Electricity (incl. plug-in hybrid)
- Hydrogen
- Natural gas (incl. biomethane)

New additions:

- most biofuels
- synthetic and paraffinic fuels
- LPG

„ZERO EMISSION VEHICLES“

Heavy duty vehicles

- without combustion engine

or

- with combustion engine emitting less than 1 g CO₂/kWh



MANDATORY PUBLIC PROCUREMENT QUOTAS FOR BUSES

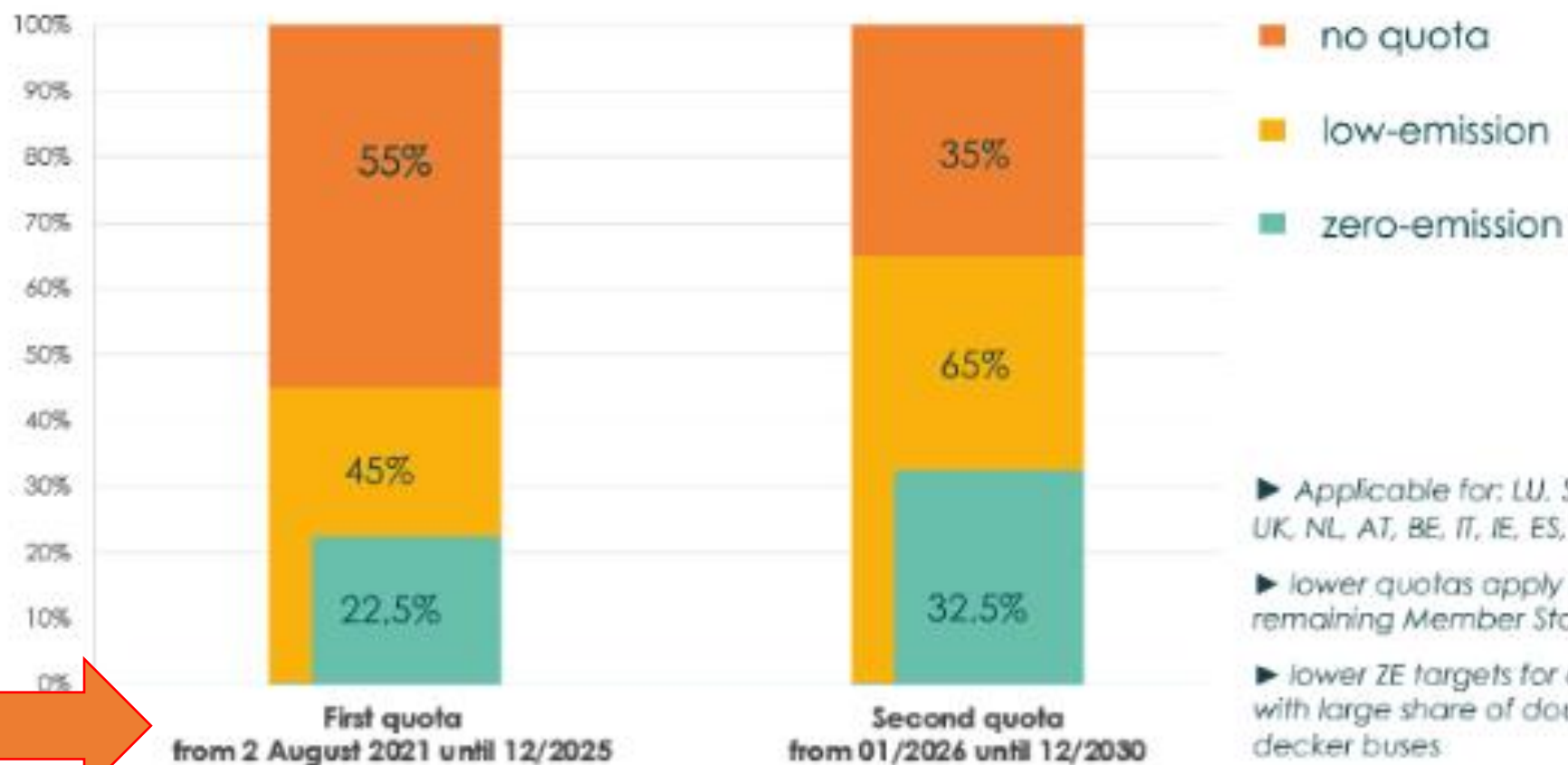

► Applicable for: LU, SE, DK, DE, UK, NL, AT, BE, IT, IE, ES, CY, MT

► lower quotas apply for remaining Member States

► lower ZE targets for countries with large share of double-decker buses



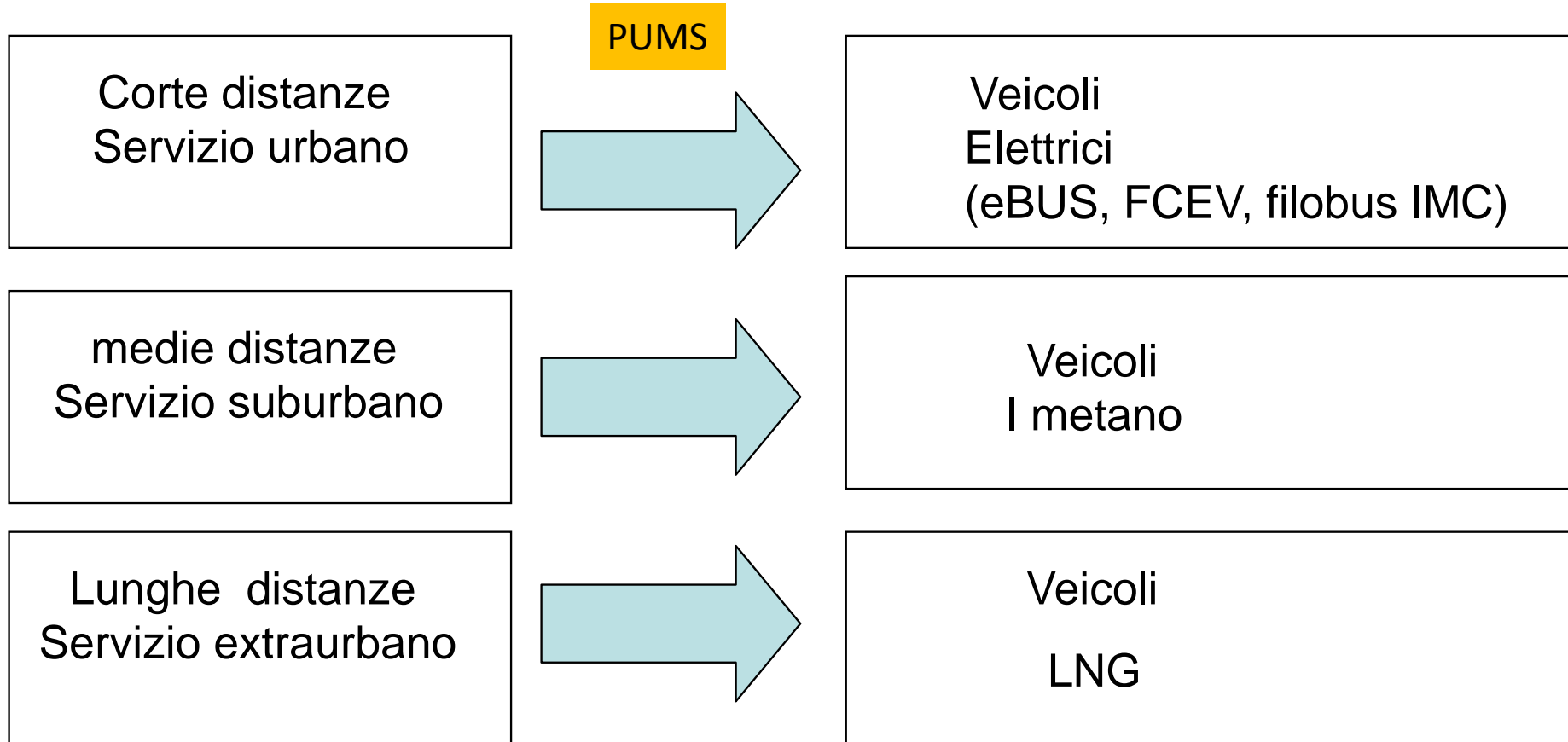

L'ambiente viene da lontano Tper spa

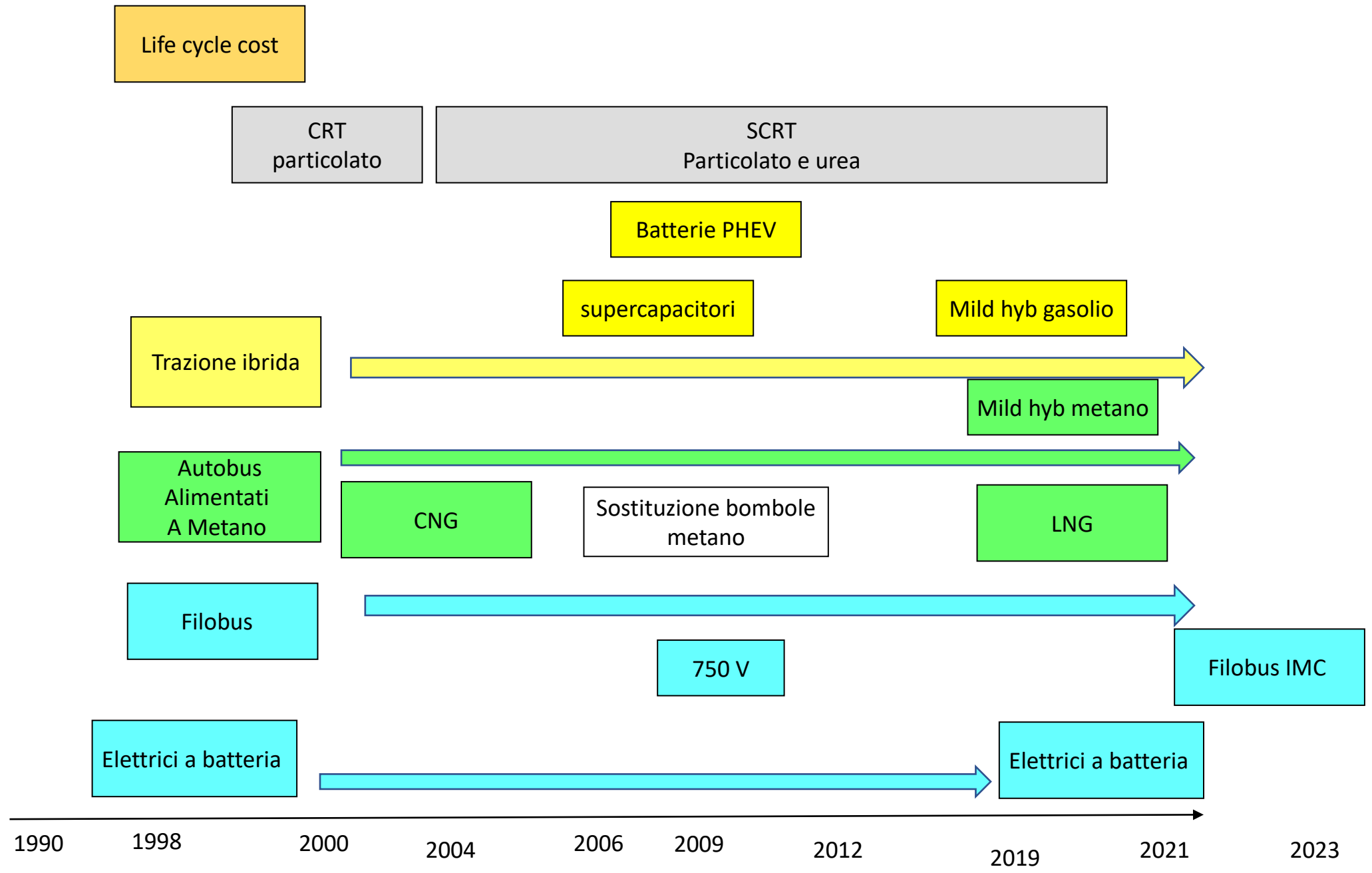

Trazione elettrica

Filobus bimodali -> full electric (PIMBO)



eBUS Overnight



eBus Opportunity charging

GHG PERFORMANCE - BIOGAS



- Biogas consistently shows outstanding GHG saving values.
- One of few fuels that actively could recycle GHG
- -73% (EU RED Directive)
- - 84 to -88% (LowCVP)
- - 97% (CONCAWE/EUCar)
- - 92% to -350% (CARB)
- The best biogas pathway (dairy waste/manure) could recycle 3x the corresponding diesel emissions. (See latest CARB data)

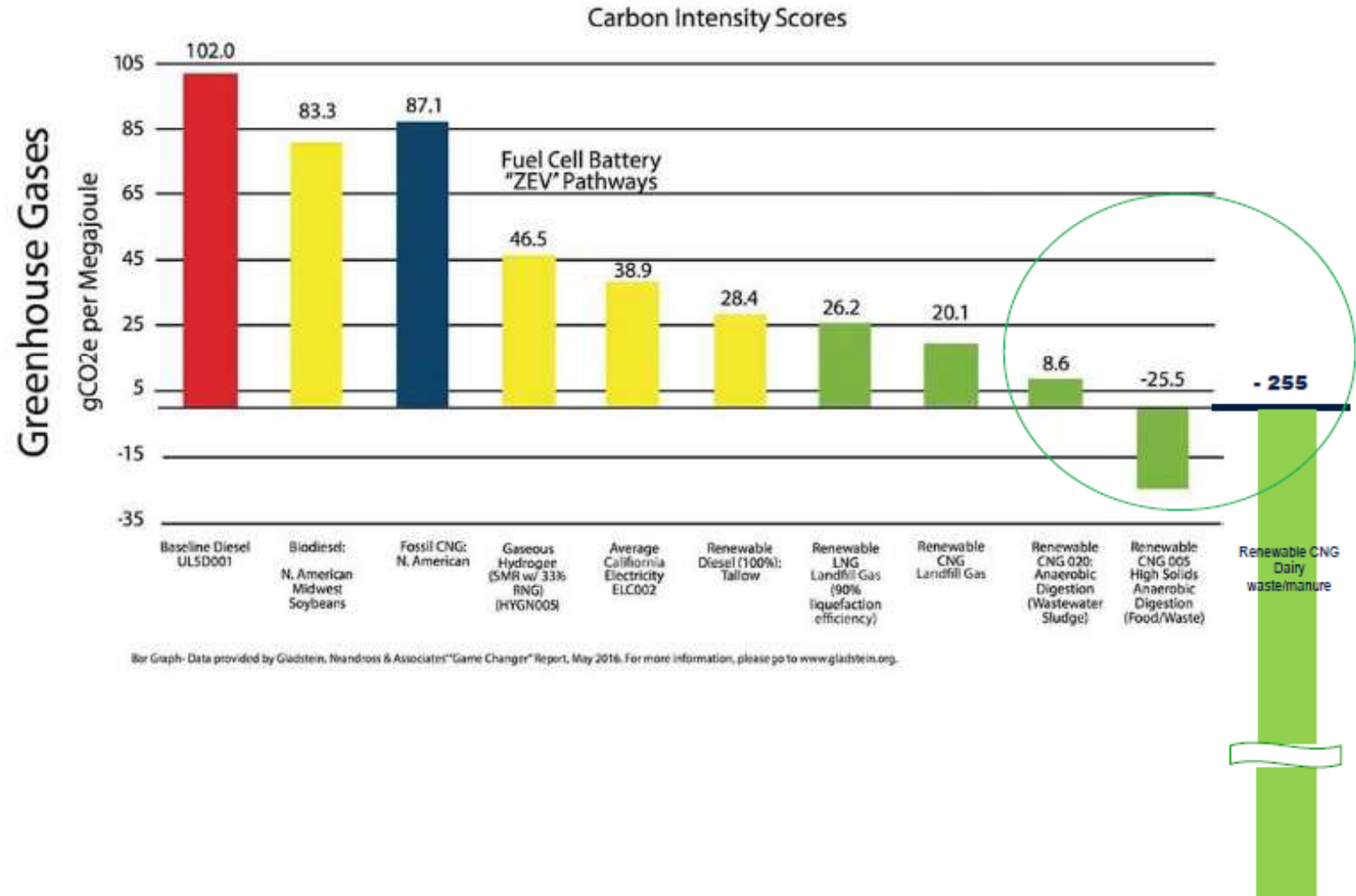

L'evoluzione del mild hybrid avvenuta in Tper spa



diesel



CNG

Il mild hybrid non ha batterie di trazione ma supercap che hanno una durata avita autobus



DROP IN FUELS
BIO CNG - BIO LNG – BIO L CNG

Ci sarà un miglioramento energetico
Con h2 al 5% nelle tubazioni gas



12 metri mid floor classe II



Tper: azienda che ha fatto della ...
scania.com



Start Romagna sulla scia di Tper: ecco ...
autobusweb.com

12 metri low floor classe I



